



Room Unit

QAW70

for use with heating controllers

Digital, multi-functional room unit for the convenient operation of heating controllers from the living room.

A setpoint knob and an economy button allow straightforward adjustment of the room temperature setpoint. The unit features a 7-day heating program, adjustable temperature setpoints, operating mode selection and an info button.

Use

Depending on the type of heating controller used, the QAW70 is specifically suited for

- single-family homes
- holiday houses

Functions

- Ergonomic and function-specific assignment of operation to 3 operating levels
- Info button for fast retrieval of important information
- Buttons for direct selection of operating mode
- Occupancy button for influencing the heating system temporarily or continuously
- Setting knob for straightforward readjustment of the room temperature setpoint
- Entry of room temperature and d.h.w. temperature setpoints
- Heating program with 3 heating periods per day; each day can be individually selected
- Holiday function

- Resetting the parameters to their default values
- PPS interface for the heating controller (with selectable device address)
- Protection of setting values against tampering (operating lock)
- Connection facility for an external switch (telephone switch)
- Connection facility for an external room temperature sensor
- Selectable display format for the setpoint (absolute / relative)

Ordering

When ordering, please give type reference **QAW70**. If an external room temperature sensor is required, it must be ordered as a separate item.

Equipment combinations

Suitable heating controllers

The QAW70 is suited for use with all types of heating controllers from Siemens HVAC Products featuring a PPS interface.

External sensor

Room temperature sensor: QAW44

Mechanical design

The room unit consists of base and operating section. The base can be mounted and wired before the operating section is fitted. Casing and base are made of plastic. The major plastic components bear the material references to facilitate environmental-friendly disposal.

Operating elements

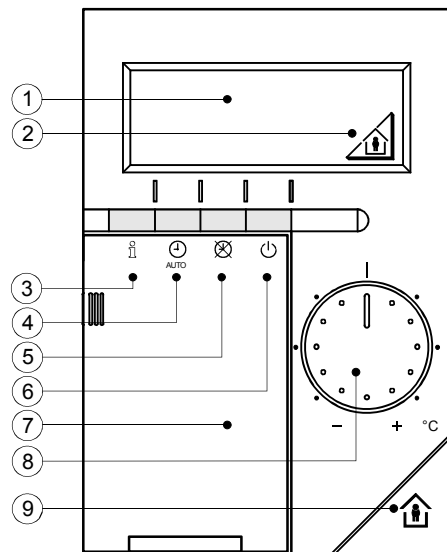

- 1 Display
- 2 Display occupancy button
- 3 Info button
- 4 Operating mode button automatic mode
- 5 Operating mode button manual operation
- 6 Operating mode button standby
- 7 Cover
- 8 Temperature setting knob
- 9 Occupancy button

Display

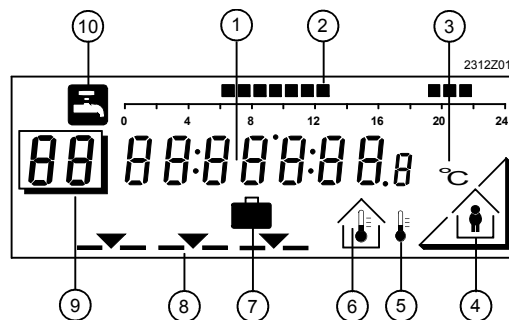

- 1 Digits, clock
- 2 Heating program
- 3 Units (°C)
- 4 Display occupancy button
- 5 Outside temperature
- 6 Room temperature
- 7 Holiday function
- 8 Operating mode
- 9 Line number
- 10 D.h.w. temperature

Operating levels	<p>The QAW70 features ergonomic and function-specific assignment of operation to 3 operating levels.</p> <p>Operation by the end-user:</p> <ul style="list-style-type: none">- Unit cover closed- Operation via info button, operating mode buttons, occupancy button and setting knob for setpoint readjustments <p>Programming by the end-user:</p> <ul style="list-style-type: none">- Unit cover open- Programming via the 4 programming buttons on operating lines 1...17 <p>Service level:</p> <ul style="list-style-type: none">- Unit cover open- This level can only be accessed by pressing a certain combination of buttons. Parameterization / programming is made possible via 4 programming buttons on operating lines 51...58
Info button	<p>Using the info button, the end-user can retrieve the following key data:</p> <ul style="list-style-type: none">- Weekday and time of day- Outside temperature- Time of day and room temperature <p>The value selected last is maintained on the display.</p>
Operating modes	<p>Three buttons are used to select the 3 available operating modes:</p> <ul style="list-style-type: none">- Automatic mode (change between the nominal room temperature and the reduced temperature according to the time switch settings)- Manual operation (nominal room temperature or reduced room temperature continuously)- Standby (frost / holiday temperature)
Occupancy button	<p>The occupancy button is used to switch from the nominal room temperature to the reduced room temperature, and vice versa.</p> <p>The action depends on the selected operating mode.</p> <ul style="list-style-type: none">- Automatic mode: changeover is only temporary; after the next switching point of the heating program, the controller will resume operation according to the settings made- Manual operation: changeover is on a continuous basis until the button is pressed again
Setpoint readjustment	<p>The temperature setting knob can be used to readjust the nominal room temperature setpoint by +/- 3 K. If required, the setting knob's readjustment range can be mechanically limited.</p>
Setpoints	<p>The following setpoints can be entered on the unit:</p> <ul style="list-style-type: none">- Nominal setpoint of the room temperature- Reduced setpoint of the room temperature- Setpoint of the d.h.w. temperature
Heating program	<p>The heating program is provided by a 7-day time switch. Each day may have a maximum of 3 heating periods whereby each weekday can be individually programmed. The heating program of the current weekday appears on the display in graphic form.</p>
Holiday function	<p>When the holiday period starts, the duration in days can be entered. During the holiday period, the room temperature is maintained at the standby level, ensuring protection against frost. If active, the holiday function is shown on the display.</p>
Default values	<p>The temperature setpoints, the heating program and the holiday function can be reset to their default values at any time.</p>

PPS interface	For heating controllers that operate 2 room units via their PPS interface, the device address can be set on the QAW70.
Operating lock	On the service level, an operating lock can be activated. When activated, it is no longer possible to change operating lines.
External sensor	The QAW70 can also be used with an external temperature sensor. The authority of that sensor can be set to between 0 and 100 %.
External switch	The use of an external switch allows changeover of the operating mode by some other device (e.g. a telephone switch). On the QAW70, it is possible to select whether the reduced room temperature or the frost / holiday mode temperature shall be maintained when the switch has closed its contact. With analog heating controllers only frost / holiday mode temperature is possible. The operating action of the switch can also be selected.
Display of setpoint	It is possible to select whether display of the setpoint shall be absolute or relative.

Notes

Engineering

- All connection terminals carry extra low voltage
- The local regulations for electrical installations must be complied with
- Sensor cables should not be run parallel to mains cables
- The room unit should be installed in the main living room
- If the control system uses room temperature influence, the room unit should be installed in a room that is representative of the entire house (reference room). If that room is equipped with thermostatic radiator valves, they must be set to their fully open position
- The mounting location should be such that the room unit can sense the room temperature as accurately as possible. This means that it should not be exposed to direct solar radiation or to other heat or refrigeration sources
- The room unit should be fitted about 1.5 m above the floor
- The room unit can be fitted on most commercially available recessed conduit boxes or directly on the wall

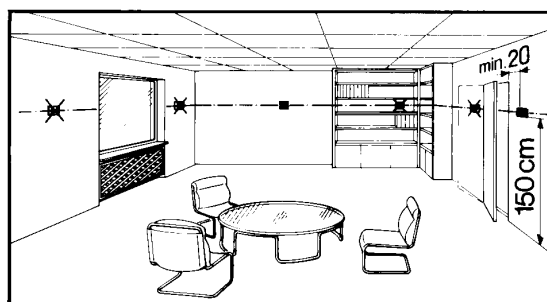

Commissioning

- Every unit is supplied with mounting and commissioning instructions

Technical data

Operating voltage	DC 10 ... 15 V
Perm. ambient temperature	
Transport and storage	-25...+65 °C
Operation	0...35 °C
Degree of protection (when mounted on a closed wall)	IP 30 to EN 60 529
Safety class	III to EN 60 730
Overvoltage protection: max. permissible voltage	
Terminals D1/D2 (PPS interface)	24 V
Terminals D3/D4 (sensor / switch)	-13 ... 5 V
Room temperature sensor	
Time constant	10 min
Coupling to the wall	50 %
Measurement range	0 ... 32 °C
Perm. cable lengths to the heating control- ler (PPS interface)	
Copper cable 0.25 mm ²	max. 25 m
Copper cable from 0.5 mm ²	max. 50 m
Perm. cable lengths to the external switch or sensor	
Copper cable 0.6 mm dia.	max. 20 m
Copper cable from 1.0 mm ²	max. 50 m
Product safety	
Automatic electrical controls for house- hold and similar use	
Special requirements on energy control- rollers	EN 60 730-1 EN 60 730-2-11
CE conformity to	
EMC directive	89/336/EEC
Immunity	EN 50 082-2
Emissions	EN 50 081-1
Low voltage directive	73/23/EEC
Safety	EN 60 730
Reserve of clock	min. 12 h
Weight (net)	0.22 kg
Colour of front	RAL 9010 (pure-white)

Connection diagrams

With an external QAW44 sensor

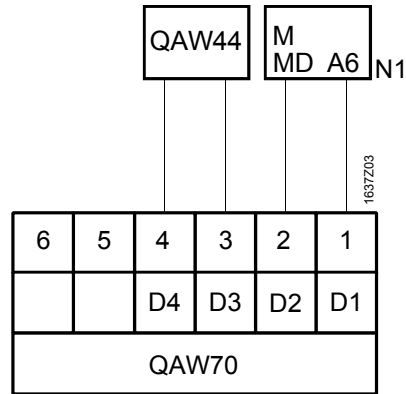

N1 = controller
D1...D4 = terminals of QAW70

With an external switch
(remote telephone switch)

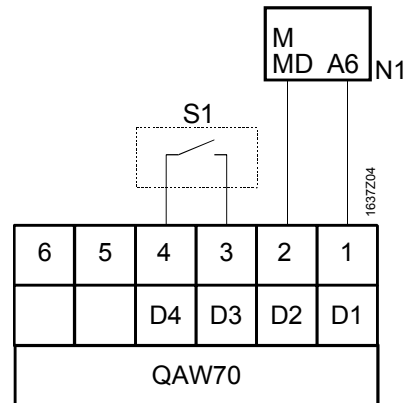

N1 = controller
D1...D4 = terminals of QAW70
S1 = external switch

Dimensions

